

17AY - Linear Actuator Stepper Motor

FEATURES

- **NEMA Size 17**
- **M5 Threaded Shaft**
- **1.8° Step Angle**
- **High Torque**
- **High Step Accuracy and Resolution**
- **Can be Customized for**
 - **Winding Current**
 - **Shaft Options**
 - **Cables and Connectors**
- **CE Certified and RoHS Compliant**



DESCRIPTION

If you are looking for a small actuator motor that is able to be customized and offers great value without sacrificing quality, then the 17AY Series Linear Actuator Stepper Motors is the one for you. This motor was designed for external linear applications that require low vibration and audible noise. The motor comes in a standard 4-lead configuration, threaded shaft, and can produce torque up to 22 oz-in. To provide flexibility, we can customize the winding to perfectly match your operating speed, voltage and current needs.

SPECIFICATIONS

Headers	NEMA Size	Bipolar Torque (oz-in)	Series Current (A)	Series Resistance (ohms)	Series Voltage (V)	Series Inductance (mH)	Rotor Inertia (oz-in-sec ²)	Screw Thread	# of Lead Wires	Weight (lbs)
17AY102S-LW4-C	17	12.5	0.55	3.2	1.76	4.5	0.0005	M5	4	0.44

Note: Other speed options, custom leadwires, cables, connectors, and windings are available upon request.

L010354

DIMENSIONS

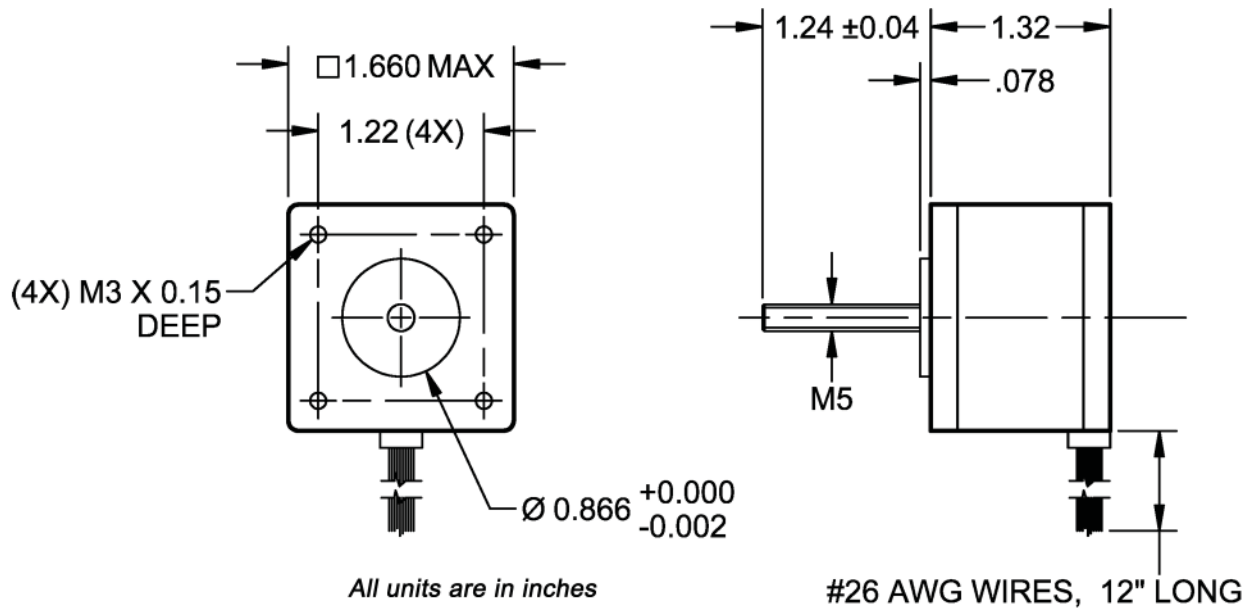

WIRING INFORMATION

Connection	Lead Wire Connection	Lead Wire Color
4 - Lead Bipolar Series MBC	Phase 1 (A)	Black
	Phase 3 (/A)	Green
	Phase 2 (B)	Red
	Phase 4 (/B)	Blue

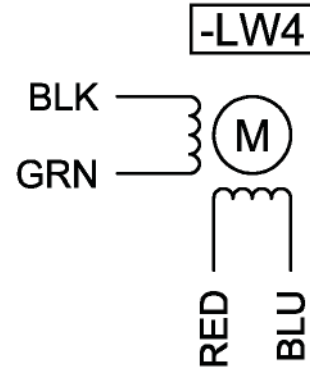

SPECIFICATIONS

Step Angle Accuracy:	±5% (Full Step, No Load)	Insulation Type:	Class B
Resistance Accuracy:	±10%	Insulation Resistance:	100M Ohm Min, 500VDC
Inductance Accuracy:	±20%	Dielectric Strength:	500VAC for one minute
Temperature Rise:	80°C Max (2 Phase On)	Max Radial Force:	4.5lbs (0.79" from flange)
Ambient Temperature:	-20° to +50° C	Max Axial Force:	2.2 lbs-Force